

INSTALLATION & MAINTENANCE INSTRUCTIONS

DESCRIPTION / IDENTIFICATION

The GX series control valve is an electronic pressure regulator designed to precisely control the pressure of gaseous media proportional to an electronic signal.

The GX1 operates using two normally closed solenoid valves, a pressure sensor, and a control circuit. One valve is actuated to allow unregulated supply media into the system. The second valve is actuated to allow working media to vent to atmosphere. The pressure sensor provides feedback to the control circuit. The control circuit compares the pressure sensor feedback to the user supplied electronic command signal and actuates the appropriate valve until the two signals match.

The GX series can be teamed with a variety of one-to-one ratio high pressure volume boosters for even greater flow. When using a volume booster, the GX2 can be used to achieve accuracy similar to the GX1 alone with higher flow capacity.

GX series product comes with a monitor output signal. This output is an electrical signal originating from the internal sensor used in the control circuit of the GX1 valve. On GX2 units this signal originates from the external transducer. This allows the system parameters to be monitored and provides a signal for data acquisition needs. This signal can be configured to either 0-10Vdc or 4-20mA sourcing.

The GX2 is similar to the GX1 but uses a double loop control scheme. In addition to the internal pressure transducer, the GX2 also receives a 0-10Vdc feedback signal from an external sensing device. The external signal functions as the primary feedback and is compared to the command signal. A difference between the two comparisons causes one of the two solenoid valves to open allowing flow in or out of the system.

A Proportion-Air DSY or DSTY will work as a second loop feedback to the GX2 (See ordering information).

The GX series has several other beneficial features. An on board split power supply allows true zero for command and monitor even though the GX is powered by a conventional single ended power supply. The GX utilizes advanced on board power management hardware to minimize current draw and heat build up. The GX also features status indicating LEDs for power and TTL. The TTL signal is a conditional on/off signal to use for diagnostic purposes. This signal is LOW when the pressure is within 1% of final setting.

PROPORTION-AIR, INC.
8250 N. 600 West
McCordsville, IN 46055

877.331.1738
info@proportionair.com



SPECIFICATIONS

ELECTRICAL

SUPPLY VOLTAGE	15-24 VDC
COMMAND SIGNAL	0-10 VDC 4-20 mA Differential
COMMAND SIGNAL IMPEDANCE	VDC=10 KΩ Current=100 Ω
ANALOG MONITOR SIGNAL	
VOLTAGE	0-10 VDC @ 10 mA max
CURRENT	4-20 mA Sourcing (only)
MAX SUPPLY CURRENT	1 Amp

MECHANICAL

PRESSURE RANGES†	Vacuum - 1,000 psig (760 mmHg (Vac) - 69 Bar)
OUTPUT PRESSURE	0-100% of range
MAX FLOW RATE	See Flow Values on page 4
Min CLOSED END VOLUME	3 in ³
PORT SIZE	1/8" NPT
FILTRATION RECOMMENDED	40 Micron (included)
RESOLUTION	<±0.10% F.S.
REPEATABILITY	<±0.15% F.S.
ACCURACY	<±0.25% F.S.

WETTED PARTS ‡

ELASTOMERS	Fluorocarbon
MANIFOLD	Nickel Plated Aluminum
VALVES	Stainless Steel
PRESSURE TRANSDUCER	Stainless Steel

PHYSICAL

OPERATING TEMPERATURE	32-158°F (0-70°C)
GX WEIGHT (Aluminum)	1.85 lbs. (0.84 kg)
GX WEIGHT (Brass)	3.15 lbs. (1.43 kg)
PROTECTION RATING	NEMA 4
HOUSING	Aluminum
FINISH	Bronze Anodized

† Pressure ranges are customer specified. Output pressures other than 100% are available. ‡ Others available

GX CONNECTION PROCEDURE

Pneumatic Connections:

1. A typical 20 micron (minimum 40 micron) in-line filter is recommended on the inlet of the GX.
2. Connect supply pressure to the “I” inlet port (figure 5) not to exceed rated supply pressure. (Table 1)
3. Connect one of the “O” outlet port (figure 6) to the device being controlled and plug the unused one.
4. Proceed with electrical connection.

TABLE 1

INLET PRESSURE FOR GX VALVES	
MAX calibrated pressure of:	Max inlet pressure is:
Vacuum up to 60 psig (<i>Vac. to 4.13 bar</i>)	150 psig (<i>10.34 bar</i>)
61 up to 120 psig (<i>4.20 to 8.27 bar</i>)	300 psig (<i>20.68 bar</i>)
121 up to 240 psig (<i>8.34 to 16.54 bar</i>)	600 psig (<i>41.36 bar</i>)
241 up to 360 psig (<i>16.61 to 24.82 bar</i>)	900 psig (<i>62.05 bar</i>)
361 up to 600 psig (<i>24.89 to 41.36 bar</i>)	1100 psig (<i>75.84 bar</i>)
601 up to 1000 psig (<i>41.43 to 68.95 bar</i>)	1100 psig (<i>75.84 bar</i>)

TABLE 2

WIRE COLOR*		FUNCTION
6M Option (GP style)	M12 (standard)	
WHITE	WHITE	COMMAND (+)
RED	PINK	ANALOG OUTPUT
GREEN	GRAY	DC COMMON
ORANGE	BROWN	TTL OUT
BLACK	BLACK	15-24 VDC POWER
BLUE	BLUE	COMMAND (-)

Electrical Connections:

1. Ensure all power is off before making any electrical connections.
2. Figure 3 shows the location of the GX electrical connector. Table 2 identifies the color codes.

Note: Both current and voltage command units require that both the command (+) and command (-) pins be connected.

3. See figure 1 and 2 for second loop connections.

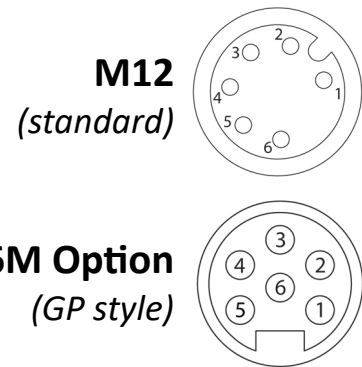

GX2 SECOND LOOP CONNECTIONS

For GX2 valves to work properly a 0-10Vdc second loop input source must be connected to the GX2.

1. Make electrical connections according to the section titled “Voltage command valves” for a voltage command unit or “Current command valves” for a current command unit
2. If Proportion-Air DS series transducer is used as the external feedback source, attach it to the auxiliary receptacle on the GX2 unit. (Figure 1)
3. If another source of transducer is used, H23 cable must be ordered to facilitate connection of that source to the GX2. (Figure 2)

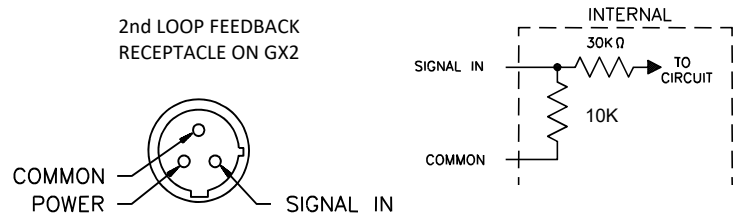

Figure 1

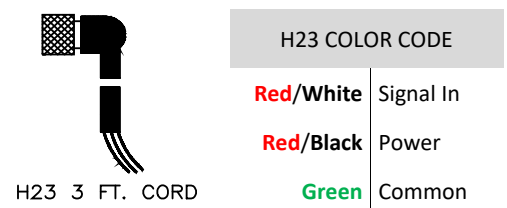

Figure 2

Note: Power & common connections on the 2nd loop receptacle are fed through from the main connector and are provided to facilitate wiring of the 2nd loop sensor.

RE-CALIBRATION PROCEDURE

All GX valves come pre-calibrated from the factory using precision calibration equipment. If the GX valve needs re-calibration, use the procedure described below:

GX1 Valves

1. Wire GX according to the section titled “Electrical Connections.”
2. Connect a precision measuring gage or pressure transducer to the unplugged outlet port of the GX.

NOTE: There must be a closed volume of at least **3 cu.in.** (49cc) between the valve outlet and the measuring device for the valve to be stable.

3. Provide supply pressure to the inlet port of the GX. (See figure 4). Make sure supply pressure does not exceed the rating for the valve. (see table 1)
4. Locate the calibration access cap on top of the GX valve and locate the ZERO and SPAN adjustment potentiometers (figure 3).

NOTE: Only use this step if your device is totally out of calibration. If it is slightly out of calibration, omit this step and move on to paragraph 7. Using a small screwdriver, turn both potentiometers 15 turns clockwise. Then turn them 7 turns counter clockwise. This will put the GX roughly at mid scale.

5. With a digital voltmeter connected to the monitor line, adjust the ZERO potentiometer until 0% monitor signal is achieved (*0.0 VDC for E monitor, 4.0 mA for S monitor*).
6. Set the electrical command input to 10 percent of full value (1Vdc for 0-10Vdc unit or 5.6mA for 4-20mA unit).
7. Set the command signal to 100% (10 VDC for E command, 20 mA for I command).
8. Adjust the SPAN potentiometer until 100% pressure output is achieved (CW increases pressure).
9. Set the command signal to 10% (1 VDC for E command, 5.6 mA for I command).
10. Adjust the ZERO potentiometer until 10% pressure output is achieved (CW increases pressure).
11. Repeat steps 7-10 until no further adjustment is required.

GX2 Valves

This calibration procedure assumes there is a properly scaled and calibrated transducer for use as 2nd loop feedback signal. (The GX2 series accepts a 0-10Vdc 2nd loop signal.)

Follow, in order, steps 1-11 as noted in the section titled GX1 VALVES. Make sure the 2nd loop is connected before you start the calibration.

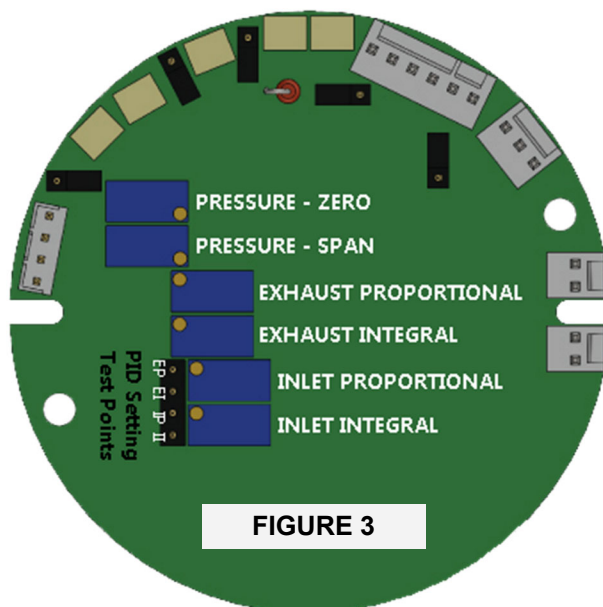

FIGURE 3

UNDERSTANDING THE POTENTIOMETERS AND PID SETTINGS

Please refer to figure 3 on the previous page for the location and identification of the GX potentiometers

PID Settings

The control circuit is split into two channels, Inlet and Exhaust. Each control channel has a Proportional Circuit, Integrating Circuit, and *Fixed Bias Circuit*.

Bias Circuit (*not field adjustable*): This is a simple voltage divider to add a fixed voltage to the valve drive signal to bias the input of the PWM IC. The PWM IC signal input range is approximately 1.24 – 3.85 vdc = 0 – 100 % duty cycle.

Proportional Circuit: This is a simple gain block with the output signal amplitude proportional to the difference of the command and feedback. The input to this circuit is the composite error signal from both the internal and external (2 loop only) error amplifiers. The relative output level is set by the proportional potentiometer.

Integration Circuit: This circuit receives the same input as the proportional circuit. This circuit acts to integrate any error signal on its input by monitoring error over time. The relative output level is set by the integral potentiometer.

Determining Current PID Settings

NOTE. The unit must not have power applied to perform the potentiometer measurements.

1. Obtain an ohmmeter and connect one lead to common.
2. With the other lead, measure and record the resistance from each test point shown in figure 3. This is the resistance between the potentiometer wiper and common and can be used to preset these parameters.

Setting PID Potentiometers

NOTE. The unit must not have power applied to perform the potentiometer measurements.

NOTE: For determining initial PID settings for a particular application, refer to the “Initial Tuning” procedure.

1. Obtain an ohmmeter and connect one lead to common.
2. With the other lead, measure and record the resistance from each test point shown in figure 2. While measuring, adjust the potentiometer to the desired setting. Repeat for all potentiometers.

Theoretical Peak Flow Values

Valve	Orifice	Approx. Cv	Max Inlet Press	Peak Flow
1	0.012"	0.004	1100 psi	2.3 SCFM
2	0.025"	0.018	1100 psi	10.5 SCFM

UNDERSTANDING THE POTENTIOMETERS AND PID SETTINGS

Please refer to figure 3 for the location and identification of the GX potentiometers

Initial Tuning for New Application

NOTE: The command and monitor circuits should already be calibrated.

NOTE: This procedure is written for an uncalibrated unit, if the unit is calibrated then the pressure zero and span adjustments need not be made.

1. Turn the four control potentiometers fully CCW.
2. Power up the unit without air pressure.
3. Adjust the pressure zero potentiometer for a reading of 0.000vdc (4.000mA), or whatever the monitor voltage should be at atmosphere for the desired calibrated range.
4. Turn the exhaust proportional potentiometer fully CW. This will allow the unit to exhaust while setting the inlet valve control levels.
5. Turn on Supply pressure and give the unit a full scale command.
6. Turn the inlet proportional potentiometer CW until the unit starts to respond and reaches about 40% of set point.
7. Turn the inlet integral potentiometer CW until the monitor signal is nearly equal to the command.
8. Fine tune the Pressure Span potentiometer if desired, The pressure does not have to be exact at this point.
9. Turn the exhaust proportional potentiometer fully CCW.
10. With the unit still at full scale pressure, give the unit a 5-10% command. (Giving a zero command will activate the positive shutoff circuit (if enabled) resulting in the over-ride of the valve drive PID potentiometers).
11. Turn the exhaust proportional potentiometer CW until the unit responds and the pressure decreases to near the set point and remains stable
12. Turn the exhaust integral potentiometer in slight increments until the pressure relieves down to set point.
13. Give the unit step changes in command and observe the response. Instability will require additional adjustment. Typically, reducing the proportional settings of either/or inlet and exhaust proportional may improve stability. It may require some trial and error to get a stable setting combination.

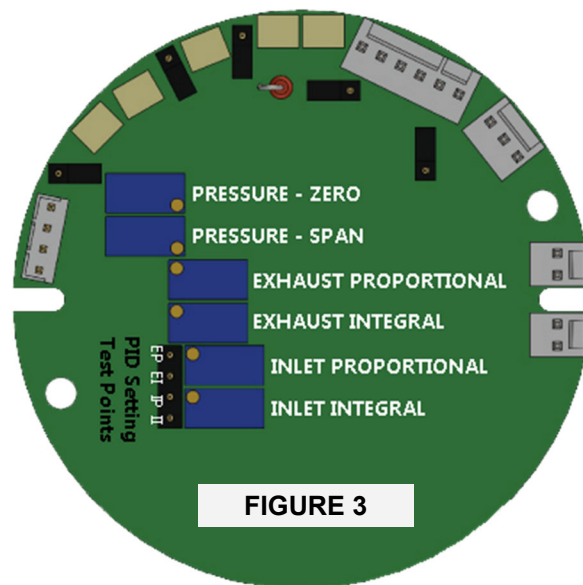

DIMENSIONS

Dimensions are for reference only

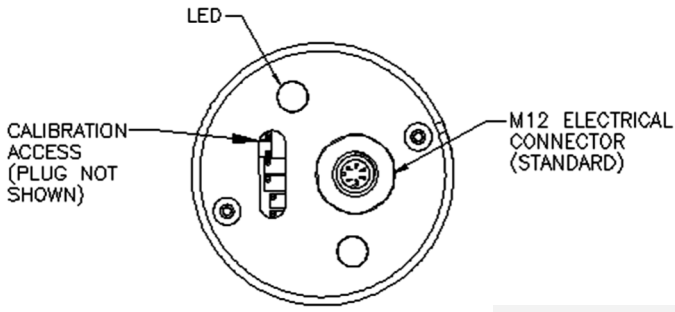

FIGURE 4

Optional foot-mount bracket show. Please use option BR to have installed at factory or order part number BKT-02 to install in-field.

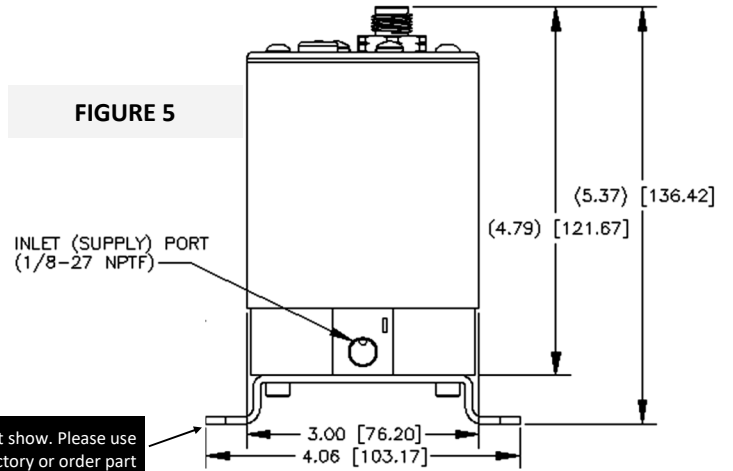

FIGURE 6

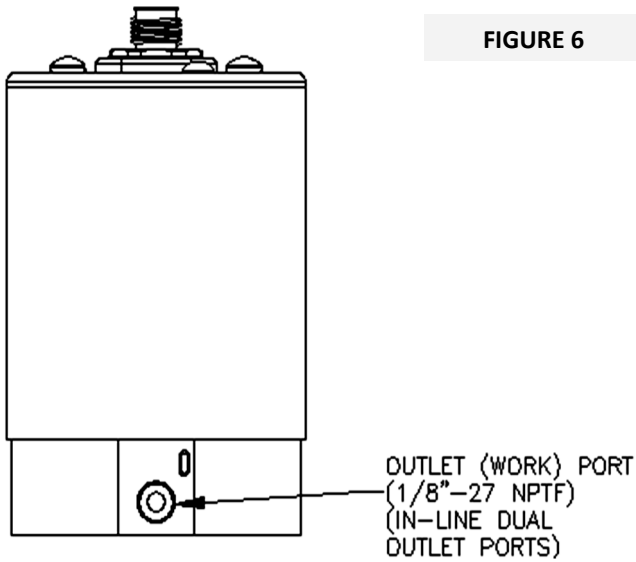

FIGURE 7

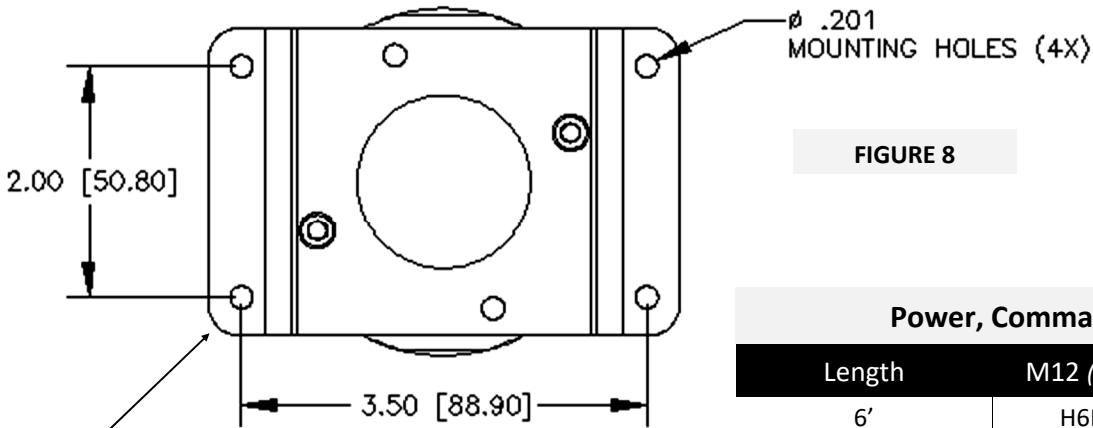
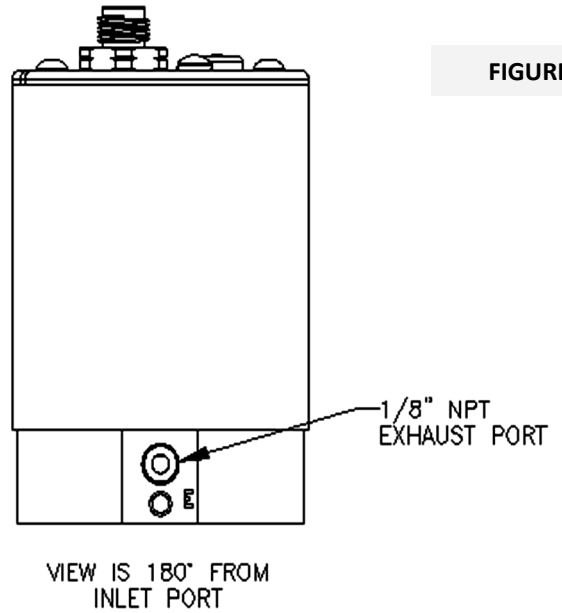

FIGURE 8

Power, Command & Monitor Cables

Length	M12 (Standard)	6M Option (Mini)
6'	H6M1206	H6DC6
15'	H6M1215	H6DC15
30'	H6M1230*	H6DC30*

*Current command & monitor units only due to distance

Optional foot-mount bracket show. Please use option BR to have installed at factory

ACCURACY		±0.25% F.S.		PRESSURE		Full Vac to 1000 PSIG (69 Bar)	
PORT SIZE		1/8"		MAX FLOW		26 SCFM (736 SLPM)	
GX	1	A	N	I	S	Z	P 69 BR G 3 3D TF
	1	2	3	4	5	6	7 8 9 10 11 12 OPTIONS

Section Reference

1	Type
1	Single Loop
2	Dual Loop

2	Manifold Material
A	Nickel-Plated Aluminum
B	Nickel-Plated Brass
S	Stainless Steel

3	Thread Type
N	NPT
P	BSPP

4	Input Signal Range
E	0 to 10 VDC
I	4 to 20 mA DC
K	0 to 5 VDC
V	1 to 5 VDC*
*Requires V for Monitor Signal (#5)	

5	Output Signal Range
X	No Monitor
E	0 to 10 VDC
K	0 to 5 VDC*
V	1 to 5 VDC* ¹
S	4 to 20 mA DC (Sourcing)
*Requires E, I or K for Input Signal Range (#4)	
* ¹ Requires V for Input Signal Range (#4)	

6	Zero Offset
N	0% Pressure is Below Zero
P	0% Pressure is Above Zero
Z	0% Pressure is Zero (Typical)

7	Zero Offset Pressure
Typical is 0* - If greater than 30% of full scale pressure (#9 below), please consult factory.	
*If Z for Zero Offset, Please Leave this Section (#7) Blank	

8	Full Scale Pressure Type
N	100% Pressure is Below Zero
P	100% Pressure is Above Zero
Z	100% Pressure is Zero

9	Full Scale Pressure
Must be less than or equal to 1,000 psig	

10	Pressure Unit (no additional fee - all)		
PS	PSI	Inches Hg	IH
MB	Millibars	Inches H ₂ O	IW
BR	Bar	Millimeters H ₂ O	MW
KP	Kilo-pascal	Kilograms/cm ²	KG
MP	Mega-pascal	Torr (Requires A for Unit of Measure #11)	TR
MH	Millimeters Hg	Centimeters H ₂ O	CW
PA	Pascal		

11	Pressure Unit of Measure
A	Absolute Pressure
G	Gauge Pressure

12	Valve Size
1	0.012"
2	1/32" (0.025")

Safety Precautions



Please read all of the following Safety Precautions before installing or operating any Proportion-Air, Inc. equipment or accessories. To confirm safety, be sure to observe 'ISO 4414: Pneumatic Fluid Power - General rules relating to systems' and other safety practices.



Warning

Improper operation could result in serious injury to persons or loss of life!

- PRODUCT COMPATIBILITY**
Proportion-Air, Inc. products and accessories are for use in industrial pneumatic applications with compressed air media. The compatibility of the equipment is the responsibility of the end user. Product performance and safety are the responsibility of the person who determined the compatibility of the system. Also, this person is responsible for continuously reviewing the suitability of the products specified for the system, referencing the latest catalog, installation manual, Safety Precautions and all materials related to the product.
- EMERGENCY SHUTOFF**
Proportion-Air, Inc. products cannot be used as an emergency shutoff. A redundant safety system should be installed in the system to prevent serious injury or loss of life.
- EXPLOSIVE ATMOSPHERES**
Products and equipment should not be used where harmful, corrosive or explosive materials or gases are present. Unless certified, Proportion-Air, Inc. products cannot be used with flammable gases or in hazardous environments.
- AIR QUALITY**
Clean, dry air is not required for Proportion-Air, Inc. products. However, a 40 micron particulate filter is recommended to prevent solid contamination from entering the product.
- TEMPERATURE**
Products should be used with a media and ambient environment inside of the specified temperature range of 32°F to 158°F. Consult factory for expanded temperature ranges.
- OPERATION**
Only trained and certified personnel should operate electronic and pneumatic machinery and equipment. Electronics and pneumatics are very dangerous when handled incorrectly. All industry standard safety guidelines should be observed.
- SERVICE AND MAINTENANCE**
Service and maintenance of machinery and equipment should only be handled by trained and experienced operators. Inspection should only be performed after safety has been confirmed. Ensure all supply pressure has been exhausted and residual energy (compressed gas, springs, gravity, etc.) has been released in the entire system prior to removing equipment for service or maintenance.



Caution

Improper operation could result in serious injury to persons or damages to equipment!

- PNEUMATIC CONNECTION**
All pipes, pneumatic hose and tubing should be free of all contamination, debris and chips prior to installation. Flush pipes with compressed air to remove any loose particles.
- THREAD SEALANT**
To prevent product contamination, thread tape is not recommended. Instead, a non-migrating thread sealant is recommended for installation. Apply sealant a couple threads from the end of the pipe thread to prevent contamination.
- ELECTRICAL CONNECTION**
To prevent electronic damage, all electrical specifications should be reviewed and all electrical connections should be verified prior to operation.

Exemption from Liability

- Proportion-Air, Inc. is exempted from any damages resulting from any operations not contained within the catalogs and/or instruction manuals and operations outside the range of its product specifications.
- Proportion-Air, Inc. is exempted from any damage or loss whatsoever caused by malfunctions of its products when combined with other devices or software.
- Proportion-Air, Inc. and its employees shall be exempted from any damage or loss resulting from earthquakes, fire, third person actions, accidents, intentional or unintentional operator error, product misapplication or irregular operating conditions.
- Proportion-Air, Inc. and its employees shall be exempted from any damage or loss, either direct or indirect, including consequential damage or loss, claims, proceedings, demands, costs, expenses, judgments, awards, loss of profits or loss of chance and any other liability whatsoever including legal expenses and costs, which may be suffered or incurred, whether in tort (including negligence), contract, breach of statutory duty, equity or otherwise.

Warranty

Proportion-Air, Inc. products are warranted to the original purchaser only against defects in material or workmanship for one (1) year from the date of manufacture. The extent of Proportion-Air's liability under this warranty is limited to repair or replacement of the defective unit at Proportion-Air's option. Proportion-Air shall have no liability under this warranty where improper installation or filtration occurred.